

BW TECHNOLOGIES

GasAlertClip Extreme 2 Year Gas Detector

Instruction Sheet

Introduction

The GasAlertClip Extreme gas detector ("the detector") is a personal safety device that warns when hazardous gas exceeds factory set alarm setpoints. The detector stores and transmits gas alarm event data. It is your responsibility to respond properly to the alarm.

Models with internal vibrator alarm and event logging	Gas Monitored
GA24XT-H	Hydrogen Sulfide (H ₂ S)
GA24XT-M	Carbon Monoxide (CO)
GA24XT-S	Sulfur Dioxide (SO ₂)
GA24XT-X	Oxygen (O ₂)

⚠ Safety Information - Read First

Warning: Substitution of components may impair intrinsic safety.

Warning: To prevent ignition of flammable or combustible atmospheres, disconnect power before servicing.

⇒ Do not activate the detector after the date on the package.

⇒ This product is a gas detector, not a measurement device.

⇒ Perform a self-test each day prior to use.

⇒ Make sure the sensor grill is free of dirt and debris.

⇒ Make sure the sensor grill is not covered.

⇒ Periodically test the sensor's response to gas by exposing the detector to a target gas concentration that exceeds the low alarm setpoint. Manually verify that the audible and visual alarms are activated.

⇒ Periodically calibrate the GasAlertClip Extreme O₂.



Note:
This instrument contains a lithium battery. Do not mix with the solid waste stream. Spent batteries should be disposed of by a qualified recycler or hazardous materials handler.

Parts of the GasAlertClip Extreme

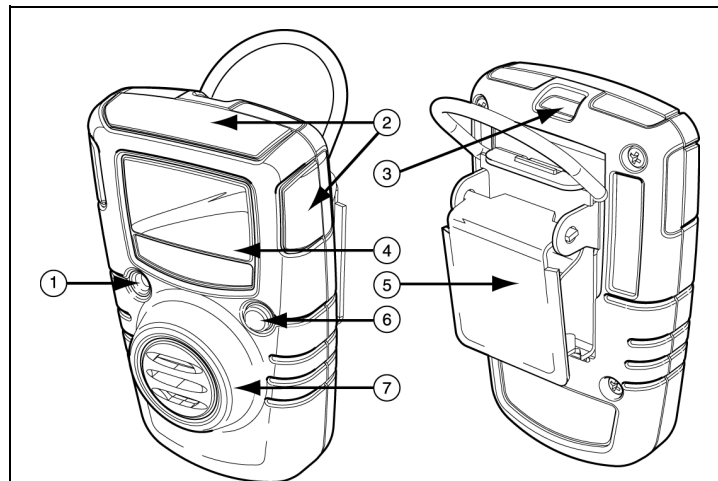

①	Audible alarm
②	Visual alarm
③	Infrared download port
④	LCD display
⑤	Clip
⑥	Start/test button
⑦	Sensor and sensor grill

Display Features

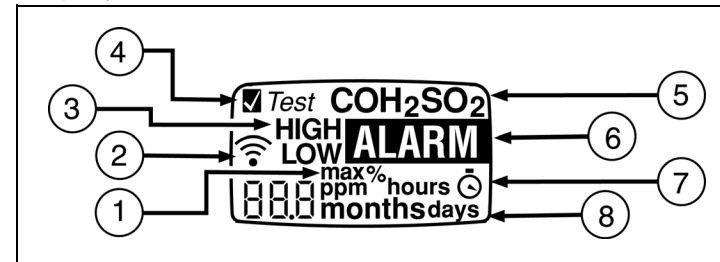

①	Maximum exposure under alarm
②	Data transmission
③	High and low alarm setpoints
④	Self-test status
⑤	Gas monitored
③ ⑥	Alarm condition
⑦ ⑧	Life-remaining indicators
① ⑧	Time since maximum exposure

Pushbutton

Pushbutton	Description
○	<ul style="list-style-type: none"> To turn on the detector, press and hold ○ for 5 seconds. Press ○ within 24 hours of receiving a gas alarm to view the maximum gas exposure. When Test is displayed, press and hold ○ for approximately 1 second to activate the self-test. To calibrate the GasAlertClip Extreme O₂, press and hold ○ for approximately 3 seconds. To display the gas alarm setpoints, press ○. To transmit the data press ○ when Prn and are displayed.

Activating the Detector

Press and hold  for 5 seconds.

Note: Once activated, the detector cannot be turned off.

Note: The detector will not respond to gas for approximately 30 seconds after the self-test.

The detector performs the actions in steps 1-5. Manually check that all the actions occur.

1. The detector emits one beep, one flash, and one vibration.
2. The detector sets the life-remaining clock.

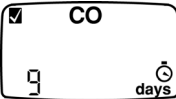

3. All LCD elements are displayed.



4. **Test** flashes while the sensor integrity and battery life are tested.
5. The low and high alarm setpoints are displayed.

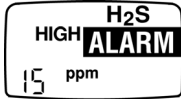
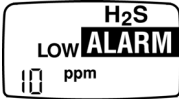

Self-Test Pass

- If the self-test passes, the detector emits a short beep and a single vibration.
-  is displayed.

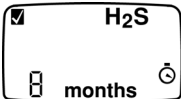

- Twenty hours after running the self-test, **Test** is displayed.

Self-Test Fail

- If the self-test fails, the detector will emit five short beeps while displaying a blank screen.
- Once the five short beeps have finished, the detector will return to the home screen with the **Test** icon displayed.
- Repeat the self-test. If the self-test fails three consecutive times, the display goes blank and the detector goes into safety shutdown mode.

Automatic Battery Test

The battery is automatically tested every 2 hours. If the battery test fails, another automatic test is initiated 30 minutes later. After five consecutive battery test failures, the display goes blank and the detector enters safety shutdown mode.

Life-Remaining Clock

The life-remaining clock indicates how much longer the detector will operate. The display shows the countdown of remaining months, then days, and then hours. The detector continues to operate for a maximum of 8 hours after the life-ended alarm (refer to the [Alarms](#) section). Press  to turn off the detector.

Safety Shutdown Mode

The display goes blank in safety shutdown mode. The detector then beeps, flashes and vibrates quickly (twice per second) until the battery loses power. To turn off the detector before the battery loses power, press . Contact your BW Technologies distributor.

The detector goes into safety shutdown mode if:

- The self-test fails three consecutive times.
- The automatic battery test fails three consecutive times.
- You do not turn off the detector manually within 8 hours of the life-ended alarm.

Gas Alarm Setpoints

The following is a list of the factory alarm setpoints.



Model	Low Alarm Setpoint	High Alarm Setpoint
GasAlertClip Extreme O ₂	19.5%	23.5%
GasAlertClip Extreme CO	35 ppm	200 ppm
GasAlertClip Extreme H ₂ S	10 ppm	15 ppm
GasAlertClip Extreme SO ₂	5 ppm	10 ppm

Note: May be equipped with customer specified alarm setpoints.

Displaying the Gas Alarm Setpoints

Press  to display the alarm setpoints.

Alarms

Display	Audible Alarm	Visual Alarm	Vibration Alarm
	Slow beeps (1 beep every second)	Slow flashes (1 flash every second)	Slow vibrations (1 vibration every second)
	Fast beeps (2 beeps every second)	Fast flashes (2 flashes every second)	Fast vibrations (2 vibrations every second)
	Slow beeps (8 beeps per minute)	Slow flashes (8 flashes per minute)	Slow vibrations (8 vibrations per minute)

Note: When the gas levels return to the acceptable range, the gas alarm stops.

Note: The life of the battery decreases rapidly under alarm conditions.

Note: The life-ended alarm occurs when the life-remaining clock displays 0 hours.

Maximum Gas Exposure

The detector records the maximum gas exposure under alarm conditions and begins calculating the number of hours since the maximum exposure occurred.

For each new exposure greater than the current maximum exposure, the detector resets the maximum gas exposure to the new level and resets hours to 0. After 24 hours of gas readings in the acceptable range, the detector resets both values to 0.

Viewing the Maximum Gas Exposure

Press  within 24 hours of receiving a gas alarm.

The detector displays the following:

- The low and high alarm setpoints.



- The maximum gas exposure and the hours since the exposure.



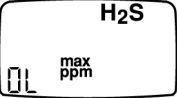

For exposures beyond the detection range, the display shows **OL**.

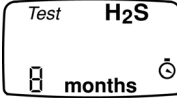

Performing a Self-Test

When it is time to perform the self-test, the display shows **Test**.





The self-test is activated prior to any feature when  is pressed and **Test** is displayed. The self-test must be performed in an atmosphere that is free of background gas.

Note: The detector will not respond to gas for approximately 30 seconds after the self-test is complete.

To perform a self-test, press and hold  for approximately 1 second.

- The detector emits one beep, one flash, and one vibration.
- All LCD elements are displayed.
- Test** flashes while the sensor integrity and battery life are tested.
- The low and high alarm setpoints are displayed.
- If an alarm occurred in the last 24 hours, the maximum gas exposure and hours since the exposure are displayed.
- Prn** and  then flashes.

Note: If you press  when the  is displayed, steps 1-3 are skipped.

To determine whether the self-test has passed or failed, refer to the [Self-Test Pass](#) and [Self-Test Fail](#) section.

Calibrating the Oxygen Detector

Once a month, the GasAlertClip Extreme O₂ flashes **CAL** and the life remaining of the detector alternately to remind you that a calibration is due. Calibrate the detector **only** in a normal atmosphere (approximately 20.9% O₂).

To calibrate the GasAlertClip Extreme O₂:

1. Press and hold  for approximately 3 seconds.
2. The detector emits one beep, one flash, and displays the following:







One vibration and a prolonged beep signifies a successful calibration. If after a second calibration attempt the beep does not sound, contact your BW Technologies distributor.

Gas Event Data Transmission

The detector stores the last 10 alarm events. The recorded data includes the serial number, life remaining, self-tests performed, total number of events and the duration of all events encountered, gas type and the alarm level (in ppm or %), time elapsed since the alarm occurred (in days, hours, and minutes), and the duration of the alarm (in minutes and seconds).

To transmit the data to a device:

1. With the receiving device on, position the detector and the device as shown in the following illustration.
2. Press  on the detector.
3. **Prn** and  will then flash. Within 5 seconds press  to begin transmission.
4. While the data is being transmitted,  will come on and  will flash. A countdown timer will display, as a percentage, how much data is left to be transmitted.

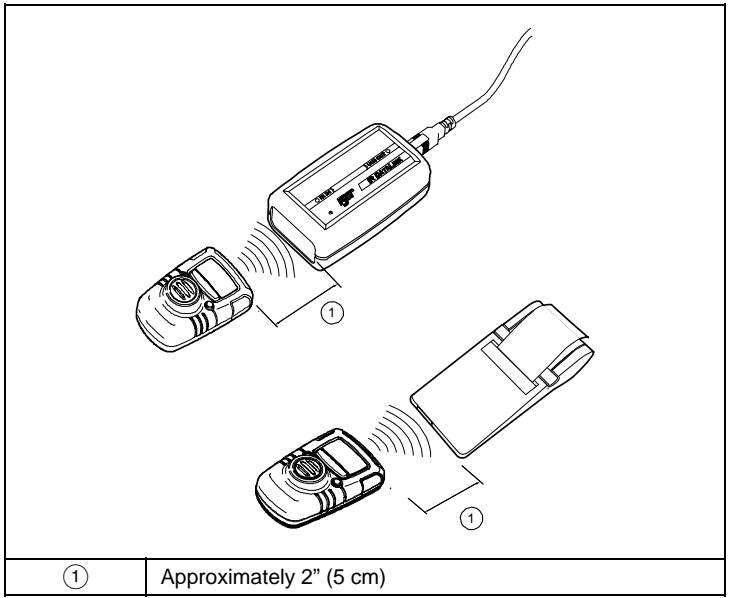

Below is a print out example from the infrared handheld printer (GPR-PRINTER2).

BW Technologies
GasAlertClip Eventlog
S/N: H303-H045792

Date:
Time:
User:

Life remaining:
 24 months

Self tests:
 2

Total events/duration:
 1 / < 1 min.

Peak exposure:
 25 ppm H₂S

Time since alarm began:
 3 mins

Alarm duration:
 8 secs

Accessories

- Test cap and hose: **GA-TC-1**
- Infrared handheld printer: **GPR-PRINTER2***
- Printer paper replacement, 3 rolls: **GPR-PP-K4**
- Automatic test station: **GA-TS02**
- GasAlertClip Extreme MicroDock II docking module: **DOCK2-GA24XT-#**
 H = Hydrogen sulfide docking module.
 M = Carbon monoxide docking module.
 S = Sulfur dioxide docking module.
 X = Oxygen docking module.
- MicroDock II automatic test/calibration station: **DOCK2-2-##-##**
 Consult your sales representative for complete order numbers and full descriptions.
- IR DataLink: **GA-USB2**
- Neck strap with safety release: **GA-NS-1**
- Alligator clip (non-conductive): **GA-AG-1**
- Alligator clip (stainless steel): **GA-AG-2**
- Hard hat clip: **GA-HC-1 (for use with alligator clip GA-AG-1 or GA-AG-2)**
- Belt clip: **GA-CL-1**
- Portable product training video: **GA-CDT1**
- GasAlertClip CD-ROM instructions: **GA24XT-CDM**

*For delivery with 220 VAC charger, add suffix (-UK) for United Kingdom, (-EU) for European, and (-AU) for Australian.

General Specifications

Shelf life	1 year before activation
Weight	76 g (2.7 oz.)
Instrument dimensions	1.1 x 2.0 x 3.2 in. (28 x 50 x 81 mm)
Operating temperature	H ₂ S: -40 to +122°F / -40 to +50°C CO: -22 to +122°F / -30 to +50°C SO ₂ : -22 to +122°F / -30 to +50°C O ₂ : -4 to +122°F / -20 to +50°C Internal vibrating option operates to: +5°F / -15°C
Operating humidity	5% to 95% relative humidity (non-condensing)
Audible alarm	≈ 95 dB at 1 ft. (30 cm)
Visual alarm	Flashing, wide-angled alarm lens with quad red LEDs plus alarm LCD readout.
Display	Liquid crystal display (LCD)
Sensor type	Electrochemical cells
Detection technique	Instantaneous alarm
Battery	Lithium, non-replaceable
Ratings and certifications	Classified by UL to both U.S. and Canadian Standards as intrinsically safe for Class I, Division 1, Group A, B, C, D and Class I, Zone 0, Group IIC ATEX: CE 0539  II 1 G EEx ia IIC T4 DEMKO 03 ATEX 0321968 IECEx CE: European Conformity ABS Type Approved VA-348-169-X
Ingress protection	IP 66/IP 67
EMI/RFI	Complies with EMC Directives 89/336/EEC

Safety Specifications

Maximum operating life	2 years after activation, assuming 3-5 minutes of alarm time/day
Detection range	H ₂ S: 0 to 100 ppm CO: 0 to 300 ppm O ₂ : 0 to 30% by volume SO ₂ : 0 to 100 ppm
Alarm setpoints	Instant low and instant high
Calibration	H ₂ S, CO, SO ₂ : Not required O ₂ : Self-calibrating

Note: This product has been classified for use in atmospheres not more than 21% v/v O₂.

Event Logging Specifications

Number of stored events	Up to 10 events encountered
Data transmission method	Via infrared port to thermal printer or via IR USB adapter to PC (for ordinary locations only)
Information transmitted	Serial number Life remaining Self-tests performed Total number and duration of all events encountered Last 10 alarm events: Gas type and alarm level in ppm or % Time elapsed since the alarm occurred in days, hours, and minutes Duration of alarm in minutes and seconds
Data transmission time	45 seconds plus 10 seconds per record

Contacting BW Technologies

To contact BW Technologies call:

- 1-888-749-8878 USA
- +44 (0) 1869-233004 Europe
- +852-2974-1783 China
- +65-9737-2005 South East Asia
- 1-800-663-4164 Canada
- +971-4-8871766 Middle East
- +61-438-887-232 Australia
- +1-403-248-9226 other countries

Corporate	USA	Europe
BW Technologies Ltd.	BW Technologies Inc.	BW Europe Ltd.
2840 - 2 Ave. SE	3279 West Pioneer Parkway	101 Heyford Park
Calgary, Alberta	Arlington, Texas	Upper Heyford, Oxfordshire
Canada T2A 7X9	USA 76013	UK OX25 5HA

Warranty

LIMITED WARRANTY & LIMITATION OF LIABILITY

BW Technologies Ltd. (BW) warrants this product to be free from defects in material and workmanship under normal use and service for a period of two years, beginning on the date of activation. This Warranty is valid only if the detector is activated by the date on the package. This warranty extends only to the sale of new and unused products to the original buyer. BW's warranty obligation is limited, at BW's option, to refund of the purchase price, repair, or replacement of a defective product that is returned to a BW authorized service center within the warranty period. In no event shall BW's liability hereunder exceed the purchase price actually paid by the buyer for the Product.

This warranty does not include:

- a) fuses, disposable batteries or the routine replacement of parts due to the normal wear and tear of the product arising from use;
- b) any product which in BW's opinion, has been misused, altered, neglected or damaged by accident or abnormal conditions of operation, handling or use;
- c) any damage or defects attributable to repair of the product by any person other than an authorized dealer, or the installation of unapproved parts on the product; or

The obligations set forth in this warranty are conditional on:

- a) proper storage, installation, calibration, use, maintenance and compliance with the product manual instructions and any other applicable recommendations of BW;
- b) the buyer promptly notifying BW of any defect and, if required, promptly making the product available for correction. No goods shall be returned to BW until receipt by the buyer of shipping instructions from BW; and
- c) the right of BW to require that the buyer provide proof of purchase such as the original invoice, bill of sale or packing slip to establish that the product is within the warranty period.

THE BUYER AGREES THAT THIS WARRANTY IS THE BUYER'S SOLE AND EXCLUSIVE REMEDY AND IS IN LIEU OF ALL OTHER WARRANTIES, EXPRESS OR IMPLIED, INCLUDING BUT NOT LIMITED TO ANY IMPLIED WARRANTY OF MERCHANTABILITY OR FITNESS FOR A PARTICULAR PURPOSE. BW SHALL NOT BE LIABLE FOR ANY SPECIAL, INDIRECT, INCIDENTAL OR CONSEQUENTIAL DAMAGES OR LOSSES, INCLUDING LOSS OF DATA, WHETHER ARISING FROM BREACH OF WARRANTY OR BASED ON CONTRACT, TORT OR RELIANCE OR ANY OTHER THEORY.

Since some countries or states do not allow limitation of the term of an implied warranty, or exclusion or limitation of incidental or consequential damages, the limitations and exclusions of this warranty may not apply to every buyer. If any provision of this warranty is held invalid or unenforceable by a court of competent jurisdiction, such holding will not affect the validity or enforceability of any other provision.